



THS-100HV HIGH VELOCITY AIR HANDLERS

Installation, Operation and Maintenance Manual

VULCANO



RADIANT North America
101 Sharer Road
Woodbridge, ON L4L 8Z3
Tel: 905-265-1527
Fax: 905-265-9739
Date issued: January 21, 2022

Contents

SAFETY INFORMATION	1
INTRODUCTION	2
Inputs: Thermostat(s)	2
Outputs:	2
PERFORMANCE RATINGS	3
THS 100 – HV Coil Data	3
THS 100-HV Blower Performance	4
Dimensional Data	4
INSTALLATION	5
Freeze Protection	6
Air Handler Mounting	6
Plumbing	7
Pump	8
PIPING DIAGRAMS	9
ELECTRICAL	11
Electrical Information	11
Thermostat Wiring	11
Air Handler Wiring Diagram	12
START-UP PROCEDURE	13
SEQUENCE OF OPERATION	14
Overview:	14
Output States:	17
Controller Logic:	18
Special Features	19
SERVICE AND MAINTENANCE	20
TROUBLESHOOTING	21
Thermostat call error	21
External pump does not run	21
External pump is noisy at start-up	22
Water heater temperature and pressure relief valve is weeping	22
Insufficient or no heat	22

Cold water at hot faucet	22
Fan runs for cooling but not for heating.....	22
Heating during standby mode.....	22
WARRANTY	23

SAFETY INFORMATION

It is the responsibility of the installer to ensure the installation complies with all national and local building codes and standards, in addition to the instructions outlined in this manual. All applicable codes take precedence over any instructions made in this document.



This symbol indicates safety alerts. When you see this symbol on labels or in this manual be alert to the potential for personal injury. Understand and pay particular attention to the signal words **DANGER**, **WARNING**, or **CAUTION**.

DANGER indicates an **imminently** hazardous situation, which if not avoided, **will result in death or serious injury**.

WARNING indicates a **potentially** hazardous situation, which if not avoided, **could result in death or serious injury**.

CAUTION indicates a **potentially** hazardous situation, which if not avoided, **may result in minor or moderate injury**. It is also used to alert against unsafe practices and hazards involving only property damage.



WARNING - Improper installation may create a condition where the operation of the product could cause personal injury or property damage. Only a qualified contractor, installer or service agency should install this product. Improper installation, adjustment, alteration, service or maintenance can cause injury or property damage. Refer to this manual for assistance



CAUTION - This product must be installed in strict compliance with the installation instructions and any applicable local, state, and national codes including, but not limited to; building, electrical, and mechanical codes.



WARNING - FIRE OR ELECTRICAL HAZARD. Failure to follow the safety warnings exactly could result in serious injury, death, or property damage. A fire or electrical hazard may result causing property damage, personal injury or loss of life.

WARNING - Hot water from a boiler used to satisfy heating requirements can be heated to temperatures of 180°F. Parts containing water this hot can scald very quickly. Use extreme caution when servicing or performing maintenance on any parts containing hot water. To avoid severe burns, allow equipment to cool before performing maintenance.

INTRODUCTION

The HV (High Velocity) hydronic air handler is designed to maximize performance and comfort in residential or light commercial applications. The air handler can be used with a variety of heat sources such as boilers and water heaters and can be implemented in combo systems that provide domestic hot water as well as space heating. Smart control systems within the air handler allow extraction of maximum heat by allowing condensing high efficiency heat sources to work at their maximum efficiency while providing ultimate comfort with unmatched performance.

The HV air handler features:

- Simple, independent airflow speed taps that can easily be set by the installer to adjust for a wide variety of installations.
- Auxiliary pump terminals, 120 VAC. Controlled by the AHU including 24 hr pump exerciser to eliminate stagnant water.
- Constant speed EC Motor.
- Integrated zone control. Up to 3 zones. Use with THS-2ZHV-2 dampers.
- Coil freeze protection
- Domestic Hot Water (DHW) priority response. When DHW is prioritized by the heat generator, the fan responds by slowing/stopping until the coil is warm again.
- Zone 1 master logic. Prevents simultaneous heat and cool calls.

Inputs: Thermostat(s)

- Continuous Fan (G) – ECM runs at lowest speed. In multi zone installations, any G opens all zones.
- Heating (W1, W2, W3) – The pump relay closes. The zone damper output associated with the call (1,2 or 3) is on (opens damper). ECM responds and fan speed increase with the length of time the call is active and the number of zones calling.
- Cooling (Y1, Y2, Y3) - The zone damper output associated with the call (1,2 or 3) is on (opens damper). ECM responds and fan speed increase with the length of time the call is active and the number of zones calling.

NOTE: Priority is given to the lowest zone number. If only 1 zone is ducted, use W1/Y1. For 2 zones use W1/Y1 and W2/Y2. Zone 1 should be the largest, most used space.

Outputs:

- Boiler Relay – a dry contact that closes on a call for heat and not Y1. 24 VAC, 1 Amp max.
- A/C interlock – an isolated 24 VAC output on when any Y is called and not W1.
- Zone damper (1,2,3) – 24 VAC output that track with the associated thermostat.

PERFORMANCE RATINGS

THS 100 – HV Coil Data

Heat Output Btu/hr @ 70 °F entering air temperature									Water PD @140 °F (ftwc)
THS 100-HV		Entering Water Temperature OF							
cfm	gpm	120	130	140	150	160	170	180	
700	4	31.4	38.3	45.3	52.5	59.7	66.8	74.0	1.3
	5	33.6	40.9	48.2	55.5	62.8	70.2	77.5	1.9
	7	36.0	43.5	51.1	58.6	66.1	73.8	81.4	3.6
800	4	33.8	41.4	49.1	56.8	64.7	72.5	80.5	1.3
	5	36.6	44.5	52.6	60.7	68.8	76.9	85.0	1.9
	7	39.8	48.1	56.4	64.8	73.2	81.7	90.1	3.6
900	4	35.7	43.9	52.3	60.7	69.1	77.6	86.3	1.3
	5	39.3	47.8	56.6	65.3	74.1	83.0	91.8	1.9
	7	43.0	52.2	61.4	70.5	79.7	89.0	98.2	3.6
1000	4	37.4	46.1	55.0	64.0	73.1	82.2	91.4	1.3
	5	41.6	50.8	60.1	69.5	79.0	88.5	98.1	1.9
	7	46.3	56.0	65.8	75.8	85.7	95.7	105.8	3.6
1100	4	0.0	48.1	57.4	66.9	76.5	86.1	95.8	1.3
	5	43.6	53.4	63.3	73.3	83.4	93.5	103.6	1.9
	7	49.1	59.4	70.0	80.7	91.3	102.0	112.7	3.6
1200	4	0.0	49.5	59.4	69.4	79.5	89.7	99.9	1.3
	5	45.5	55.7	66.1	76.7	87.3	98.0	108.8	1.9
	7	51.6	62.7	73.9	85.1	96.5	107.8	119.2	3.6

THS 100-HV Blower Performance



Dimensional Data

PHYSICAL DATA inches)											
Model	Overall Size (W x D x H)			Supply Air Opening Dia Height		Return Air Opening (W x H)				Pipe Location distance from top	
	A	B	C	D	E	F	G	H	I	J	K
THS 100- HV	21	21	29	10 (zones 2 & 3 = 8" dia)	1.8	18.3	14.3	1.4	2	3.7	6.3

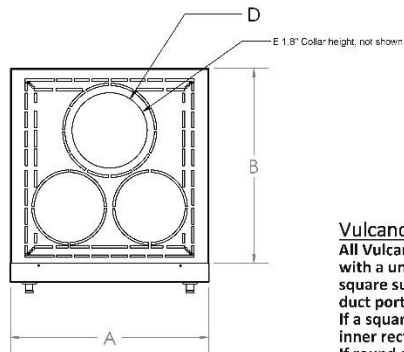

Vulcano THS Series AHU's Universal Top
 All Vulcano THS Series Air Handlers are equipped with a universal top to accommodate both a square supply plenum opening, OR round supply duct ports.
 If a square plenum opening is desired, cut out the inner rectangle section and fold flange 90°. If round duct ports are desired, cut out **Zone 1** and install the collar supplied. If additional zones are required cut them out in order.

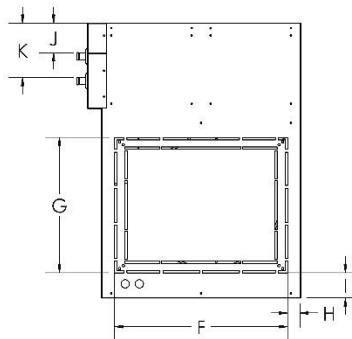
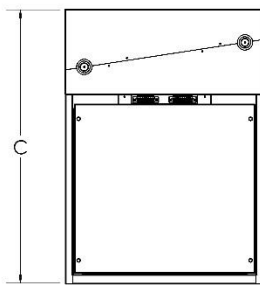
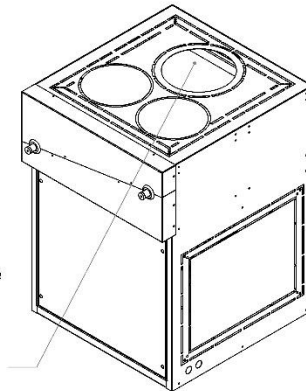

MODEL	THS 100-HV
Dx Cooling Capacity (Ton)	2 to 3
Electrical (V/Ph/Hz)	120/1/60
Cabinet size (W x D x H) (in)	21x21x29
Supply Air Opening (in)	10 / 8
Return Air Opening (in)	18.3x14.3
Recommended Filter Size (in)	16x20
Shipping Weight (lb)	98
Shipping dimensions WxDxH (in)	22x24x30

INSTALLATION

The installer must comply with all local and national code requirements pertaining to the installation of this equipment.

Clearances

The air handler is approved for up-flow, down-flow, and horizontal configurations. Clearances do not change with orientation. This hydronic furnace is for indoor installation only.

All Models	Clearances from Combustibles (in)	Recommended Service Clearance minimum (in)
Top	0	0
Bottom	0	0
Front	0	24
Back	0	0
Sides	0	0

Freeze Protection

It is not recommended to install the air handler in an unheated space.

Should the air handler be installed in an area where the ambient temperature may fall below freezing, ethylene or propylene glycol should be added into the hydronic heating system to protect against damage, which would not be covered under warranty. Make sure the glycol is compatible with all system components and is permitted by local and national codes.

Air Handler Mounting

The air handler can be installed in up flow, down flow and left or right horizontal applications. Install the air handler with the door in place to make sure the cabinet remains square. Flip the unit for down flow applications so that the top of the unit is now the bottom. No modification is required for any configuration.



CAUTION - Use any of the existing screw holes in the cabinet when using straps. If the existing screw is too short for securing a mounting strap, a longer screw should be used provided care is taken not to damage any internal components. Product warranty does not cover any damage or claims resulting from damage from longer screws or from the unit being improperly suspended

The cabinet is designed so that the return air can be located on either side of the cabinet. Position a filter rack so that the filter is readily accessible. A filter and filter rack are not included. Sides are marked for a standard 16 x 20 in filter rack.



WARNING - Special care should be taken in the vicinity of the coil to avoid puncture. Screw into opening flange instead of top of cabinet when fastening the supply air duct.

Plumbing

Install a ½ in sediment faucet or ball valve for use as a drain/purge valve. The drain valve must be located downstream of the pump and check valve, and upstream of the isolation valve (if isolation valve is present). With this arrangement, any air trapped in the system can easily be flushed out following the instructions in the Start-up & Troubleshooting sections. Isolation valves are recommended, but not required. Installing isolation valves facilitates easy servicing.

When the space heating loop connections are made to the domestic water connections:

- The heating loop connections should be positioned horizontally in a vertical section of the domestic water line for both inlet and outlet. Refer to the piping schematic for details.
- Connect the heating loop to the domestic water connections as close to the water heater as possible

Avoid sections of pipe in the heating loop that can trap air where possible. It is usually impossible to install a system without having at least one part of the system or heating coil able to trap air. This will not be a problem if the connection to the domestic water lines is made properly, and purge valves and air eliminator devices are installed.

- Following the flushing procedures in the start-up section will ensure that there is no air in the system after initial set-up.

Follow recommendations supplied by the manufacturer of the heating source being used. The air handler includes a flow switch connection where a flow switch can be connected to allow for domestic water priority. Note: the correct type of flow switch is a normally open (NO) device. The flow switch closes when domestic water is flowing.

Check Valve

A check valve may be required for your system to meet local codes and to work effectively. A check valve:

- Protects against backflow of water to avoid short circuiting around the water heater during domestic use
- Protects against thermal siphoning (spring loaded check valve)
- Is required in all potable water systems

A drain pan is recommended underneath the appliance for all installations.

The coils of the THS series air handlers are further equipped with vent and drain plugs at the highest and lowest points.

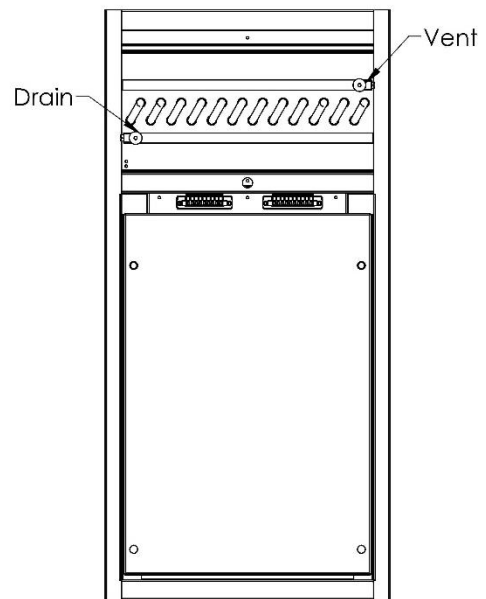

Pump

A pump is not included inside the air handler. Whether you are using an external pump or an internal built-in pump, it should be sized for the system. Pumps supplied with the heat generating units can be used as the sole pump provided it meets the needs of the system. This is especially the case in retrofit applications where a much larger pump may have previously been used in the system.

- The pump will operate as a single-speed pump.
- The air handler controller has a built-in pump timer that exercises the pump for 1 minute every 24 hours to prevent stagnant water.

Water Heater or Boiler Setup

Follow the manufacturer's installation and start-up instructions of the water heater or boiler. Make sure the equipment is turned off during installation and service. Make certain the equipment has been refilled and all air is purged from the system before turning on the heater.



WARNING - When the system requires water temperatures higher than 125°F, a mixing valve shall be installed to reduce domestic hot water temperature to safeguard against scalding.

Combo Systems

The air handler is ideal for use in combo systems which provide space heating and domestic hot water from a single heat source. Any properly sized gas, propane or oil-fired water heater or boiler will work in a combo system. Make sure any water heater being used is approved for combo applications.

PIPING DIAGRAMS

Heating Only Boiler Piping

Typical installation for an air handler for R1K Series Boilers.

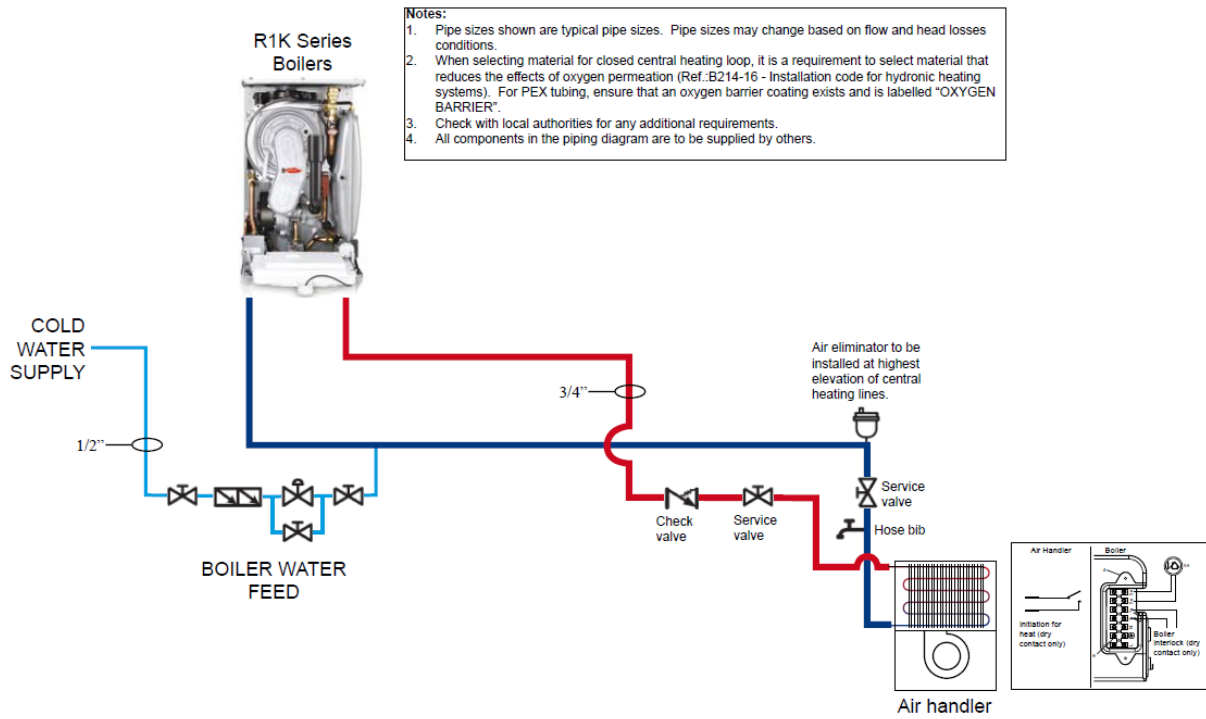

Combi-Boiler Piping

Typical piping installation for an air handler and domestic hot water for R2K Series Boilers with mixing valve, dhw re-circulation and drain water heat recovery unit.

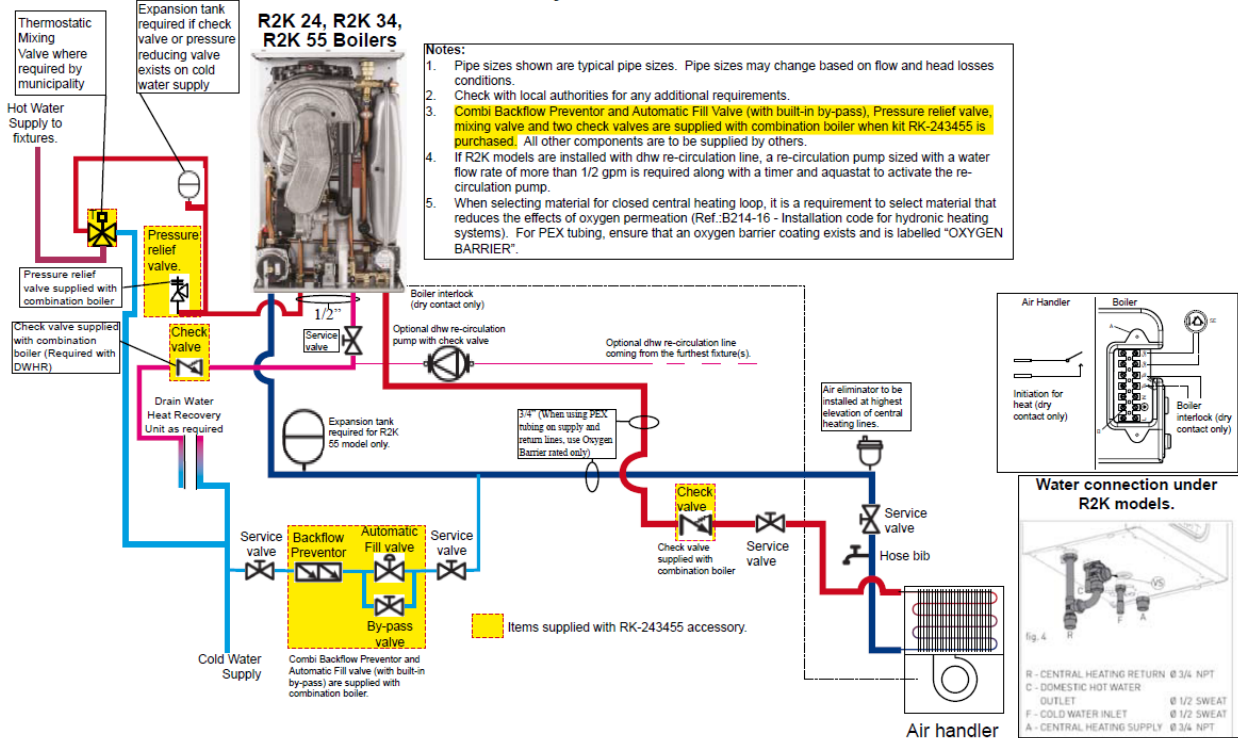

ELECTRICAL



WARNING - Make sure the installation meets all national and local electrical codes.

Electrical Information

- The air handler operates on 120VAC 60Hz single phase line voltage and should have its own dedicated breaker or fuse rated as per the MOP on the ratings label
- All control circuits are 24VAC
- The air handler must be grounded at the lug in the electrical box.



- Use a quality ratchet crimping tool to ensure reliable connections

Thermostat Wiring

Any standard heat/cool thermostat is compatible with the air handler.

'Smart' thermostats usually require an uninterrupted 'C' connection (see wiring diagram below).

Wire the thermostat(s) to 9-pin green terminal (left).

Air Handler Wiring Diagram

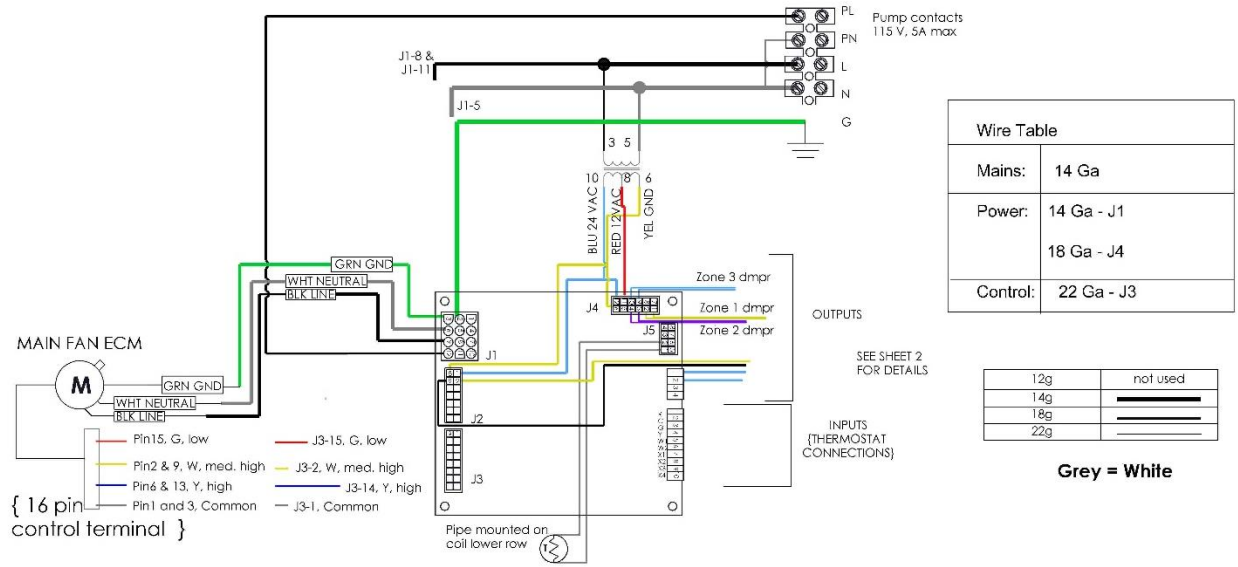

START-UP PROCEDURE

1. Fill the system with water. Do not start the system.
2. Purge all air from the system. Isolation and purge valves are strongly recommended.
3. Purge all air from the space heating loop by closing the isolation valve on the return leg of the loop and open the drain to purge air. Open the return leg isolation valve and then close the drain valve.
4. Start the hot water generating equipment per the manufacturer's recommendations.
5. Set the water temperature to deliver the necessary to achieve the design heat loss.
6. Once all air has been purged, turn on the power to the air handler and set the room thermostat to heat and set the temperature high enough to initiate a call for heat. This will energize the air handler and in turn the fan and pump.
7. Once the heat source is supplying hot water, check supply and return pipes for a temperature difference to make sure there is flow. There should be a noticeable difference in temperature between supply and return lines. Use caution when supply water temperature is above 125°F / 51°C.

SEQUENCE OF OPERATION

Controller LED Status:

The air handler main control board is equipped with 2 LED indicators.

LED 1. When the board is powered, in any state, LED 1 is illuminated Green.

LED 2. When the board is powered and there is a closed contact on any thermostat input, LED will be illuminated Red. If the thermostat was not calling at start up, this may indicate a short in the control wiring or faulty thermostat. If no calls are present when the air handler is powered up, LED 2 will be green.

Overview:

External Inputs	Function	Circuit board connection (J7)
R	24VAC power	R
C	24VAC common	C
G	Fan relay	G
Y1	Compressor contactor (Master)	Y
W1	Heat relay (Master)	W1
W2	Heat relay (Slave 1)	W2
Y2	Compressor contactor (Slave1)	X1
W3	Heat relay (Slave 2)	X2
Y3	Compressor contactor (Slave2)	X3

External Outputs	Function	Circuit board connection
BR-1	Boiler Switch (dry contact)	RSW (J6)
BR-2		RSW (J6)
D1-1	Zone Damper 1 (24 VAC)	1 (J4)
D1-2		2 (J4)
D2-1	Zone Damper 2 (24 VAC)	4 (J4)
D2-2		3 (J4)
D3-1	Zone Damper 3 (24 VAC)	10 (J4)
D3-2		9 (J4)
Yc	Isolated Condenser Contacts	2 (J2)
Cc		9 (J2)

Blower:

1. During a demand for cooling, the isolated condenser contacts will activate when the inlet temperature of the water coil is greater than 3°C to assist in preventing the water coil from freezing. The blower will energize. When the inlet temperature of the water coil less than 3°C freeze protection mode is active. The isolated condenser contacts open, the boiler switch closes, the pump contacts close and the fan remains on to defrost the coil. Freeze protection mode remains on for at least 3 minutes and until the coil temperature is greater than 3°C.
2. During a demand for heating, the blower will de-energize if the inlet temperature of the water coil is less than 25°C to prevent cold drafty air supply during a priority call of domestic hot water to the combination boiler. The blower will activate when the inlet temperature of the water coil is greater than 28°C.
3. On a demand for heating the activation of the blower will be delayed by 15 seconds.
4. Low Speed:
 - a. The blower will circulate at low speed when "G" is energized at any zone (G1, G2, and G3).
 - b. The blower will run at low speed for the first 5 minutes of single demand for heating from any zone (W1, W2, and W3).
5. Medium speed:
 - a. The blower will run at medium speed between 5 minute and 10 minutes of any single demand for heating from any zone (W1, W2, and W3).
 - b. The blower will run at medium speed for the first 5 minutes of single demand for cooling from any zone (Y1, Y2, and Y3). This will provide dehumidification to conditioned space.
 - c. The blower will run at medium speed for the initial 10 minutes for any two demands for either heating or cooling (W1, W2, W3, Y1, Y2, and Y3).
6. High speed:
 - a. The blower will run at high speed after any single demand for heat that has exceeded 10 minutes (W1, W2, W3) and after any single demand for cooling that exceeded 5 minutes (Y1, Y2, and Y3).

Pump: (if external pump is installed)

1. The pump will circulate for any heating demand. There is a post purge time of 45 seconds after a demand for heating has been satisfied. (W1, W2, and W3).
2. The pump will circulate when the inlet temperature of the water coil is less than 3°C to assist in preventing the water coil from freezing. The pump will de-energize after 3 minutes and the inlet temperature of the water coil is greater than 3°C (Y1, Y2, and Y3).
3. The pump will circulate for one minute after 24 hours of being idol.

A/C Interlock:

1. The A/C Interlock is ON for any cooling demand (Y1, Y2, and Y3) without a higher priority zone call for heat. For example, Y1 on and W2 on A/C interlock is On. Y2 on and W1 on, A/C interlock is OFF.

2. The A/C Interlock is OFF for any heating load (W1, W2, and W3) without a higher priority Y. Similar to 1 above.
3. For freeze protection, if the inlet water supply temperature sensor reads a temperature of 3°C or less, the A/C Interlock is OFF. The freeze protection mode will end after 3 minutes and the temperature of the inlet water supply temperature sensor is above 3°C (Y1, Y2, and Y3).

Zone 1 damper:

1. The damper is never completely closed. The closed position is ~25% open.
2. Zone 1 is the master zone and any demands from Zone 1 will dictate heating or cooling modes.
3. The Zone 1 damper is ON for any call of heating or cooling demand for Zone 1 (W/Y1, W/Y2, and W/Y3).
4. The Zone 1 damper is ON for any fan on demand for any zone (G1, G2, or G3).

Zone 2 damper:

1. The damper is never completely closed. The closed position is ~25% open.
2. The Zone 2 damper is ON for any call of heating or cooling demand for Zone 2 (W/Y1, W/Y2, and W/Y3).
3. The Zone 2 damper is ON for any fan on demand for any zone (G1, G2, or G3).

Zone 3 damper:

1. The damper is never completely closed. The closed position is ~25% open.
2. The Zone 3 damper is ON for any call of heating or cooling demand for Zone 3 (W/Y1, W/Y2, and W/Y3).
3. The Zone 3 damper is ON for any fan on demand for any zone (G1, G2, or G3).

Boiler Switch:

1. The boiler switch is a dry contact and is ON for any heating demand for any zone without a cooling demand from a higher priority zone. Ex. If W3 is on, the boiler switch is on. Or if W1 and Y2 are both on, the boiler switch is on.

Note: See the table on the following page for all combinations of inputs and outputs.

Output States:

		Zone1 (red)	Zone2 (orange)	Zone3 (blue)	Low (green)	Medium (white)	Boiler (blue)	Pump (orange)	A/C (green)
1	Goff/W1off/Y1off/W2off/Y2off/W3off/Y3off								
2	Goff/W1off/Y1off/W2off/Y2off/W3off/Y3on								
3	Goff/W1off/Y1off/W2off/Y2off/W3on/Y3off								
4	Goff/W1off/Y1off/W2off/Y2on/W3off/Y3off								
5	Goff/W1off/Y1off/W2on/Y2off/W3off/Y3off								
6	Goff/W1off/Y1on/W2off/Y2off/W3off/Y3off								
7	Goff/W1on/Y1off/W2off/Y2off/W3off/Y3off								
8	Goff/W1off/Y1on/W2off/Y2on/W3off/Y3off								
9	Goff/W1on/Y1off/W2off/Y2on/W3off/Y3off								
10	Goff/W1off/Y1on/W2on/Y2off/W3off/Y3off								
11	Goff/W1on/Y1off/W2on/Y2off/W3off/Y3off								
12	Goff/W1off/Y1off/W2off/Y2on/W3off/Y3on								
13	Goff/W1off/Y1off/W2on/Y2off/W3off/Y3on								
14	Goff/W1off/Y1on/W2off/Y2off/W3off/Y3on								
15	Goff/W1on/Y1off/W2off/Y2off/W3off/Y3on								
16	Goff/W1off/Y1off/W2off/Y2on/W3on/Y3off								
17	Goff/W1off/Y1off/W2on/Y2off/W3on/Y3off								
18	Goff/W1off/Y1on/W2off/Y2off/W3on/Y3off								
19	Goff/W1on/Y1off/W2off/Y2off/W3on/Y3off								
20	Goff/W1off/Y1on/W2off/Y2on/W3off/Y3on								
21	Goff/W1on/Y1off/W2off/Y2on/W3off/Y3on								
22	Goff/W1off/Y1on/W2on/Y2off/W3off/Y3on								
23	Goff/W1on/Y1off/W2on/Y2off/W3off/Y3on								
24	Goff/W1off/Y1on/W2off/Y2on/W3on/Y3off								
25	Goff/W1on/Y1off/W2off/Y2on/W3on/Y3off								
26	Goff/W1off/Y1on/W2on/Y2off/W3on/Y3off								
27	Goff/W1on/Y1off/W2on/Y2off/W3on/Y3off								

Controller Logic:

Inputs	Device	Onboard marker			
R	all thermostats R	R	+	And	
C	All thermostats C	C	!	Not	
G	All thermostats G	G		Or	
Y	Thermostat 1 Cooling	Y			
W	Thermostat 1 Heating	W1			
W2	Thermostat 2 Heating	W2			
Y2	Thermostat 2 Cooling	X1			
W3	Thermostat 3 Heating	X2			
Y3	Thermostat 3 Cooling	X3			
Th1 (in Celsius)	Thermister 1	W _{mode}	W W2+!Y W3+!Y+!Y2		
Th2 (in Celsius)	Thermister 2	Y _{mode}	Y Y2+!W Y3+!W+!W2		
		Gal _{one}	G+!W+!Y+!W2+!Y2+!W3+!Y3		
		X _{neg}	Thermostat turn off activity		
		DamperX Delay Timer	20 seconds		
THS_Radiant States					
Blower					
OFF	Low (5)	Med (4)	High (3)	OFF (Highest Priority)	
default	G	Y _{mode} <5 min	Y _{mode} >5 min	W _{mode} +Th1<25,	
	W _{mode} <5 min	5 min<W _{mode} <10 min	W _{mode} >10 min	end when Th1>28	
		W+W2			
		W+W3			
		W2+W3			
Pump					
OFF	ON	OFF			
default	W _{mode}	Y _{mode}			
	Th1<3				
	Ex (1min if idol for 24hours)				
	W _{off} (45s after W _{mode} call off)				
Boiler Switch					
OFF	ON	OFF			
default	W _{mode}	Y _{mode}			
	Th1<3				
A/C interlock					
OFF	ON	OFF			
default	Y _{mode} +Th1>3	Th1<3			
(Zone 1 damper)				(Zone 1 damper Off Delay Timer)	
OFF	ON	OFF	OFF	ON	OFF
default	Gal _{one}		default	Gal _{one neg}	
	W			W _{neg}	
	Y			Y _{neg}	
	Damper1 Delay Timer				
(Zone 2 damper)				(Zone 2 damper Off Delay Timer)	
Off	ON	OFF	OFF	ON	OFF
default	Gal _{one}		default	Gal _{one neg}	
	W2 + !Y			W2 _{neg}	
	Y2 + !W			Y2 _{neg}	
	Damper2 Delay Timer				
(Zone 3 damper)				(Zone 3 damper Off Delay Timer)	
OFF	ON	OFF	OFF	ON	OFF
default	Gal _{one}		default	Gal _{one neg}	
	W3+!Y+!Y2			W3 _{neg}	
	Y3+!W+!W2			Y3 _{neg}	
	Damper3 Delay Timer				

Special Features

Condenser Lockout/Freeze Protection

The air handler is equipped with a condenser lockout / freeze protection sensor to help prevent any damage to the hot water coil from a freeze up. In any mode, heating, cooling or standby, when the coil temperature is 3°C or lower the air handler will energize the pump relay and boiler switch and open the A/C interlock, turning off the condenser unit.

Pump Exerciser

The circulating pump is exercised for 1 min if there has been 24 hours without activity.

SERVICE AND MAINTENANCE

NOTE: The air handler is not to be used for temporary heat during construction. Use for this purpose will void equipment warranty.

Filter

Inspect the filter monthly and replace, remove and vacuum or rinse as required. A clogged or inadequate filter may void product warranty. Replacement filter size is 16 x 20 x 1.

Coils

Air conditioning and heating coils should not require cleaning if the filter maintenance schedule is adhered to. If a filter is damaged or collapses from plugging, dust may foul the coils. If this happens, replace the filter and carefully vacuum the coils. The fan may need to be removed to gain access to the face of the heating coil.

Fan and Motor

Check fan for dust once a year. If dirty, vacuum or wash to remove dust. Keeping the fan blades clean will reduce noise and improve capacity and efficiency of the heating system.

TROUBLESHOOTING

Removing blower/control assembly

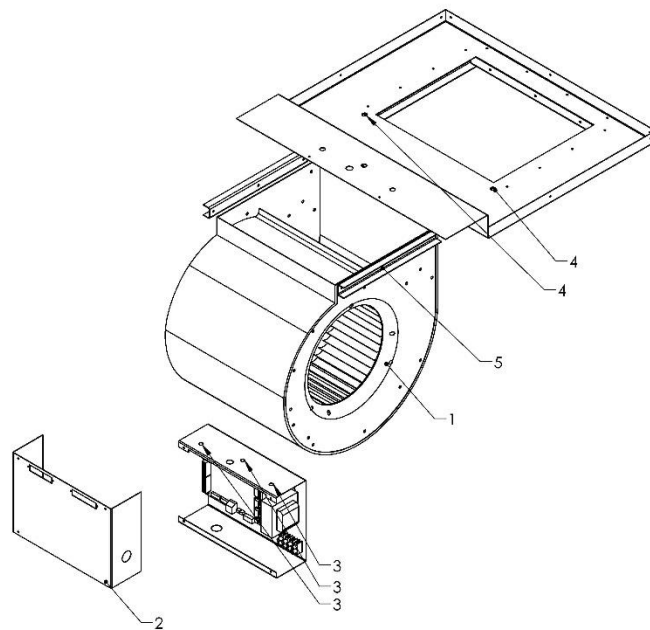

1. Unplug the ECM, not shown
2. Remove electrical box cover, 4 screws
3. Drop electrical box, 2 bolts 10x24.
4. Release the blower from the divider plate, 2-10x24 bolts
5. Slide blower out on rails

Thermostat call error

If the air handler does not run when the thermostat is calling, jumper R to W for heating or R to Y (Y2) to verify if the problem is with the thermostat or with the air handler control. Note that some thermostats have a delay (typically five minutes) before they will re-start cooling to prevent compressor damage.

External pump does not run

In areas where hard water is present the pump may stick and fail to run. Often, closing the isolation valve on the return leg and opening the drain port so that water flows through the pump can free this. If this fails to free the pump, removal for cleaning or replacement is necessary. The daily pump exerciser will help prevent pump sticking.

External pump is noisy at start-up

If sound has not diminished within 1 minute, air may be present in the system and may need re-purging. If the heat source is a water heater, check to make sure branch connections for the heating loop are horizontal to prevent the collecting of air in the loop.

Water heater temperature and pressure relief valve is weeping

A check valve or back-flow preventer may have been installed in the system. Some form of pressure relief may be required. Consult water heater manufacturer's instructions. Options are:

- Install expansion tank
- Install pressure relief valve; locate outlet over laundry tub or floor drain

Insufficient or no heat

- Check that the heat generator is functioning properly
- Plugged air filter or coil. Refer to maintenance section for filter care and coil cleaning
- Air in heating loop - purge system
- Inlet and outlet connections to the air handler are backwards - reverse connections
- Water heater dip tube is restricted or damaged; check and/or replace
- Supply water temperature set too low or not calibrated properly - check water temperature
- • Restrictions on heating loop - remove restrictions, check if valve is stuck, isolation valves could be too restrictive or left partially closed after purging, or a closed valve

Cold water at hot faucet

When the heat source is a water heater, the most probable cause is reverse flow through the heating loop from a stuck check valve - repair or replace valve.

Fan runs for cooling but not for heating

The room thermostat may be connected improperly. Refer to Electrical section or wiring schematic on the air handler for proper installation.

Heating during standby mode

Probable cause is thermal siphoning. Make sure piping elevation instructions shown in piping drawings have been followed. Repair or replace check valve. Check elevation of the air handler above water heater to see if motorized valve required for positive shut-off.

WARRANTY

1 year standard parts.